



Last name:

First name:

Student number:

---

# Question 1)

Points: .....

Maximum points: 12

Name four cloud services (only platform and infrastructure services are allowed!) you used for solving the exercise sheets. Also explain in a few words which functionality of these services you used. It should become clear why you used each single service.

Name of service	Sort of service	Explain the functionality you used and also the reason for using the service
	<input type="checkbox"/> PaaS <input type="checkbox"/> IaaS	
	<input type="checkbox"/> PaaS <input type="checkbox"/> IaaS	
	<input type="checkbox"/> PaaS <input type="checkbox"/> IaaS	
	<input type="checkbox"/> PaaS <input type="checkbox"/> IaaS	

Last name:

First name:

Student number:

# Question 2)

Points: .....

Maximum points: 12

- $PR_p$  = PageRank of a web page  $p$
- $L_{IN}(p)$  = Set of documents, which refer to  $p \implies$  incoming links
- $L_{OUT}(p)$  = Set of documents, to which  $p$  refers  $\implies$  outgoing links
- $d$  = damping factor between 0 and 1

$$PR(p) = (1 - d) + d * \sum_{p_i \in L_{IN}(p)} \frac{PR(p_i)}{\text{amount } L_{OUT}(p_i)}$$

Calculate the missing iterations of the PageRank algorithm for the given example scenario with  $d = 0.8$ .

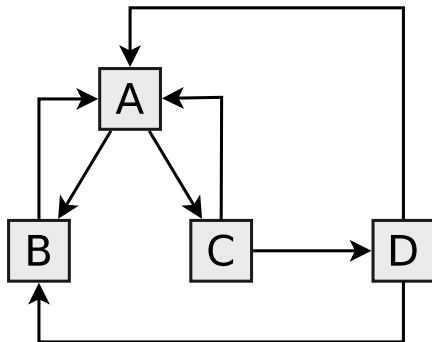

	0	1	2	3	4	5	PR
A	1		1.48		1.5184		1.553216
B	1		1.16		1.096		1.071424
C	1		0.92		0.8688		0.852416
D	1		0.44		0.5168		0.522944

Last name:

First name:

Student number:

---

## Question 3)

Points: .....

Maximum points: 7

- a) Think about a scenario, when a service provider creates a new service offering, which allows the customers to deploy virtual machines and specify their network configuration. What sort of cloud offering is this?
  
- b) Think about a scenario, when a service provider creates a new service offering, which is basically an email client in the browser. What sort of cloud offering is this?
  
- c) Think about a scenario, when a service provider creates a new service offering, which provides a scalable runtime environment for a programming language. What sort of cloud offering is this?
  
- d) Think about a scenario, when a service provider creates a new service offering, which allows the customers to create virtual block storage devices. What sort of cloud offering is this?
  
- e) Think about a scenario, when a service provider creates a new service offering, which is basically an office solution in the browser. What sort of cloud offering is this?
  
- f) Think about a scenario, when a service provider creates a new service offering, which allows the customers to store any files as web objects and make them accessible via the internet. What sort of cloud offering is this?
  
- g) Think about a scenario, when a service provider creates a new service offering, which converts print jobs. The users send print jobs to the service and do not need to install printer drivers locally. What sort of cloud offering is this?

Last name:

First name:

Student number:

---

## Question 4)

Points: .....

Maximum points:  $1+2+2+1=6$

During the semester, you had to select one free software solution of a given list, do some investigation about it and prepare a presentation.

- a) Name the free software solution you did select and investigate.
  
- b) What is the application purpose of the software you did select?  
*(In other words: What can a user do with this software?)*
  
- c) Name two benefits of the software you did investigate in contrast to other (similar) software solutions („competitor solutions“).  
*(It is required that you also name the competitor solutions.)*
  
- d) Name one drawback of the software you did investigate in contrast to other (similar) software solutions („competitor solutions“).  
*(It is required that you also name the competitor solutions.)*

Last name:

First name:

Student number:

---

## Question 5)

Points: .....

Maximum points: 10

During the semester, you had to select one free software solution of a given list, do some investigation about it and prepare a presentation.

Draw a diagram of the important components of the software you did investigate. Please also insert information (e.g. arrows) in the diagram which explains how these components interact with each other, with the operating system and with the users.

Last name:

First name:

Student number:

---

## Question 6)

Points: .....

Maximum points: 1+3=4

a) Name and explain one technical reason which caused many providers of cloud gaming service offerings to get out of business?

b) Name and explain three reasons for the failure of P2P streaming projects.





Last name:

First name:

Student number:

# Question 8)

Points: .....

Maximum points:  $1+1+0.5+5+0.5=8$

- a) What is the drawback of linear search in the Chord ring?
- b) What way of searching in the Chord ring is preferred?
- c) To which node  $n$  gets a key  $k$  assigned to?
  - Direct predecessor
  - Direct successor
  - First node (starting from ID 1) without any keys assigned yet
- d) Calculate the Finger Table values of node  $n = 2$  and insert the correct values into the provided Finger Table.

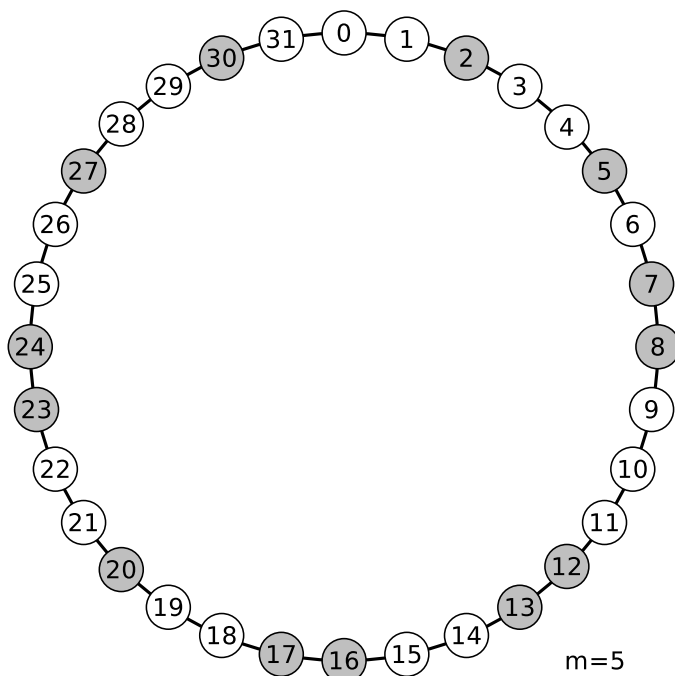

Finger Table of node  $n = 2$

Entry	Start	Node
1		
2		
3		
4		
5		

The table has 5 entries, because  $m$  contains the length of the ID in bits and  $m = 5$

The Start value of entry  $i$  of the table on node  $n$  is  $(n + 2^{i-1}) \bmod 2^m$

The Node value of entry  $i$  points to the first node, which follows to  $n$  at a distance of at least  $2^{i-1}$

- e) Which node is responsible for the key (resource) with ID 21 ?



Last name:

First name:

Student number:

---

## Question 10)

Points: .....

Maximum points: 3+3=6

a) How long does it take to transfer 100 TB via a 6 Gbps (= 6,000 Mbps) Ethernet?

b) What is the height of a stack of storage media, if for storing 2 PB of data DVDs (capacity: 4.3 GB =  $4.3 \times 10^9$  Byte, thickness: 1.2 mm) are used?

Last name:

First name:

Student number:

---

## Question 11)

Points: .....

Maximum points: 3+3=6

Company X runs 500 computer workplaces.

- Scenario 1: Fat clients (PC)
  - Electrical power rating per desktop: 500 watts
  - Electrical power rating per screen: 100 watts
  
- Scenario 2: Thin clients
  - Electrical power rating per thin client: 40 watts
  - Electrical power rating per screen: 100 watts
  - Electrical power rating per server blade: 500 watts
  - Each server blade has enough resources to run 30 virtual desktops

What are the electricity costs per year for 24/7 operation when the electricity price is 0,30 €/kWh?